

TSB # 842-0060  
Prince Castle  
355 East Kehoe Blvd  
Carol Stream, IL 60188  
Date 04/04/2018

Dear Customer / 3wire,

In an ongoing effort to ensure quality on our Genuine OEM Equipment, we are Issuing a Technical Service Bulletin for our UHC Holding Cabinet Series. Please read the notification and detailed information below.

**Notification:**

Effective 3/31/2018 all versions of 547-058s have surpassed their warranty extension. Any claims submitted after 3/31/2018 with 547-058s versions will be rejected. Any defective 547-058s versions will continue be replaced by 547-303s versions as an out warranty parts replacement.

**Units effected:**

- Unit Manufacture Serial Date Codes prior to CH (03/2013)
- All UHC series unit with 547-058s type versions depicted below.

**547-058s Depicted Below**

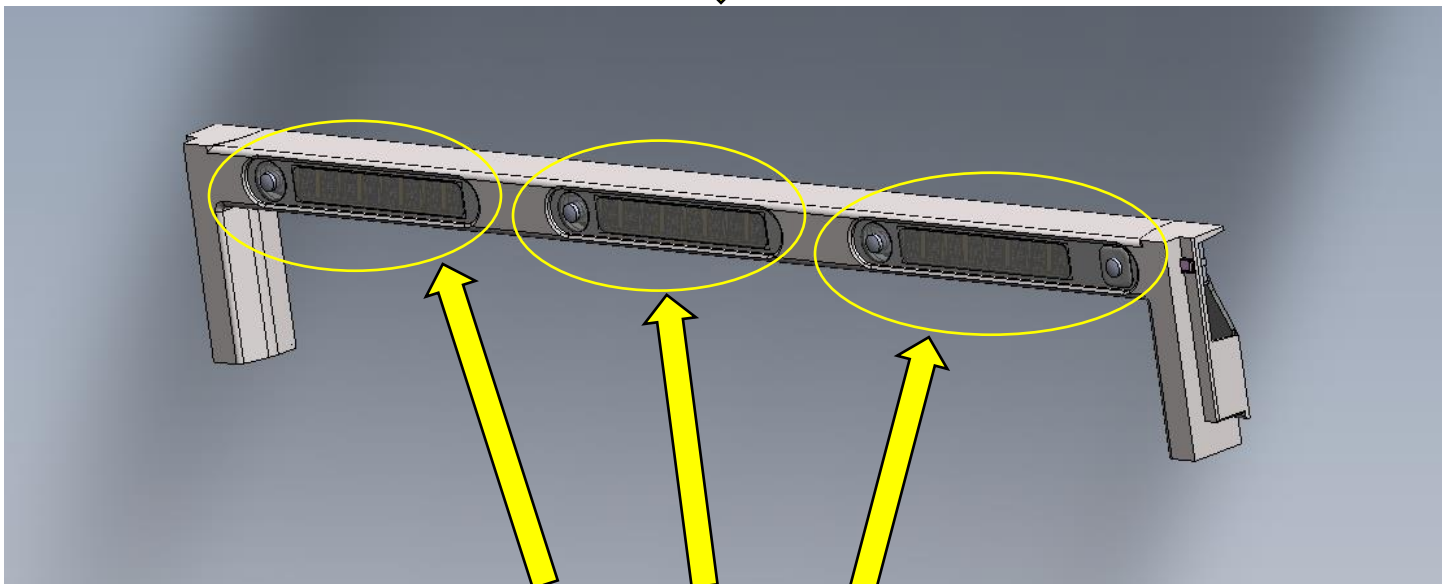

Please note recessed LED segment windows

TSB # 842-0060  
Prince Castle  
355 East Kehoe Blvd  
Carol Stream, IL 60188  
Date 04/04/2018

**Procedure:**



Have customer follow the current bezel replacement procedure below. If unit has 547-058s version bezels proceed with an out of warranty parts replacement. If unit has 547-303s bezels, evaluate if unit is covered under warranty and proceed with appropriate actions.



### Prince Castle Bezel Replacement Procedure

**All steps be followed to receive replacement bezels. If process is not followed replacement bezels will not be shipped.**

1. Call 1-844-800-1495 for UHC Technical Support and provide your email address to the Agent.
2. An auto generated email with a Ticket number will be sent after the initial phone call.
3. Reply to this email with the following information:
  - o National Store Number
  - o Ticket Number provided in auto email
  - o Serial Numbers for each faulty bezel listed in the body of the email.
  - o Picture of Equipment serial number label, located on the back side of the UHC.
    - Refer to photo with Green Arrow for ex-ample.
  - o Picture of the front and back side of each unit.
    - The entire unit must be visible for both pictures.
    - Refer to photo with Red Arrows for exam-ple.
4. Prince Castle Technical Service will review pictures and approve or seek additional information.
5. If approved, authorization will be provided to ship the bezels to the McDonalds location via 2nd Day Air.



Sincerely,



Paul Svenningsen  
Technical Service Manager U.S.