



Vertical Artisan Toaster Product # DCFT-ART

Prince Castle's Dual Continuous Feed Toaster is the next generation of vertical bread toaster, providing operators with perfect bun caramelization. With its space-saving/contemporary kitchen design, the DCFT an increase bun throughput while decreasing the cost of ownership through patented advances in platen and conveyor technology.

Equipped with separate bun compression controls for crown and heel, the DCFT can toast a wide variety of sizes and types of carriers (core buns, specialty buns, etc.) without a decrease in performance or product quality. By toasting the face of buns and breads, sugars are caramelized and the end result is hot and moist toast with a "fresh out of the oven" presentation. Driving all of this is a brushless, continuous-duty DC motor which is fully enclosed and sealed with longlife lubrication, eliminating the need for monthly maintenance.

By reducing the amount of expensive consumables used by competitive units (such a rubber conveyor belts) into an approximate 65cm (w) x 64cm (h) x 40cm (d) footprint, the Dual Continuous Feed Toaster from Prince Castle improves toast quality and throughput while significantly decreasing the cost of ownership to the operator.

Product Features

- Toast core buns and specialty rolls in one toaster
- Adjustable speed, temperature, and compression adjustment for multiple bread products
- Stainless steel belt for lifetime reliability
- Release sheet is the ONLY consumable
- Tilt out access doors for easy maintenance
- SNAP™ design for rapid servicing and trouble-shooting
- Heated landing zone for core buns
- Gold quality toasting at only 500° F for low current draw and power consumption
- Compatible with 1 & 3 phase wiring

Optional Motorized Butter Wheel

- Motorized butter wheel ensures the proper amount of butter is dispensed every time.
- Removable butter tray ensures safe, sanitary food preparation, as well as ease of cleaning.
- Stainless steel construction for durability.
- Reduces waste of expensive butter.





Vertical Artisan Toaster

Product # DCFT-ART

Dimensions

Model Number	Width in (cm)	Height in (cm)	Depth in (cm)	Shipping Weight lbs (kg)	Shipping cu.ft. (cu.m)
DCFT-ART-MCDCE	9.4 (23.9)	25.3 (64.3)	17.3 (43.9)	75 (34)	TBD
DCFT-ART-MCDNA	9.4 (23.9)	25.3 (64.3)	17.3 (43.9)	75 (34)	TBD
DCFT-BWART-MCD	15.1 (38.4)	7.6 (19.3)	4.6 (11.68)	TBD	TBD

Electrical

Model Number	Volts	Hz	Amps	Plug Configuration
DCFT-ART-MCDCE	200 - 240	50/60	20	Mennekes 148A
DCFT-ART-MCDNA	200 - 240	50/60	20	Mennekes 320P6W
DCFT-BWART-MCD	N/A	N/A	N/A	N/A

Specifications

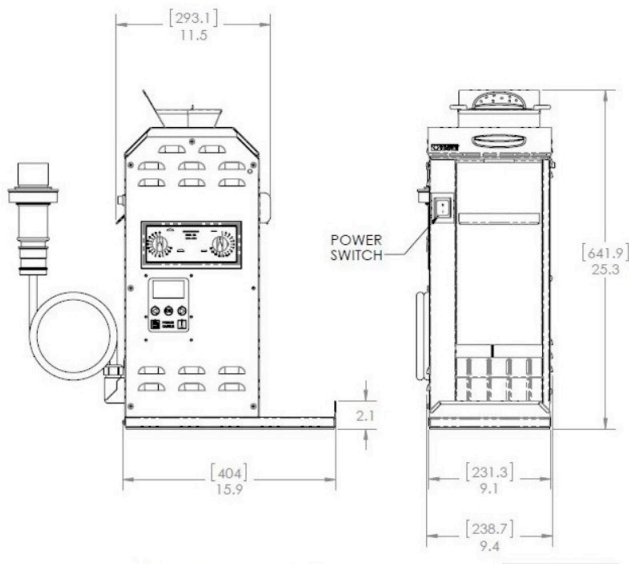

DCFT-ART-MCD Series

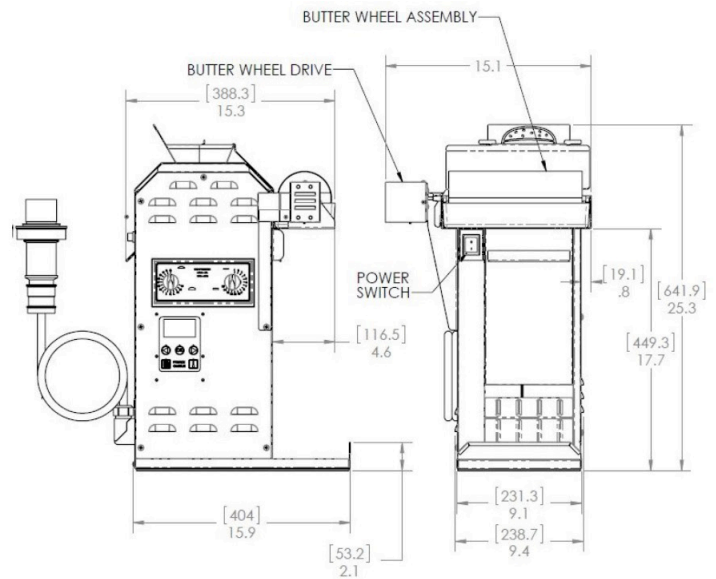

DCFT-ART-MCD Series With Butter Wheel

Certifications



MARMON
A Marmon/Berkshire Hathaway Company

© 2018 Prince Castle LLC - Specifications and design are subject to change without notice

This product is patent protected. Patent information can be found at www.princecastle.com/patents/.



355 E. Kehoe Blvd.
Carol Stream, IL 60188

1.800.PCASTLE • 630.462.8800
www.princecastle.com