

Features

- **Toast core buns and breakfast items simultaneously**
- **Adjustable compression, speed, and temperature controls**
- **Stainless steel belt for long term reliability**
- **Minimal low cost consumables**
- **Sliding belt drawer for easy cleaning and maintenance**
- **Modular design for rapid servicing and troubleshooting**
- **Heated landing zones for core buns**
- **Gold quality toasting at only 455° (vs. over 550°)**
- **Breakfast items are fed into UHC tray to minimize product handling**
- **Dual sided club toasting**
- **Compatible with single and three phase wiring to eliminate in-store electrical wiring**
- **Low energy consumption with high bun temperatures**

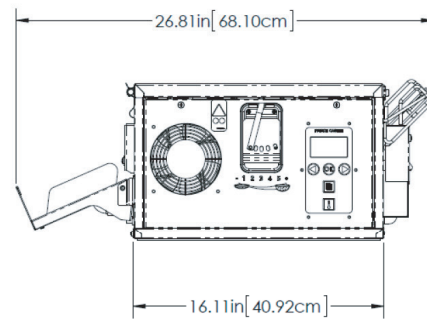
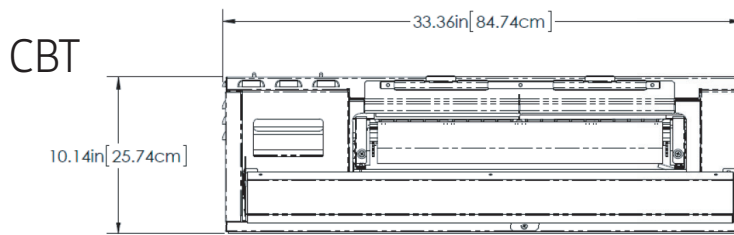
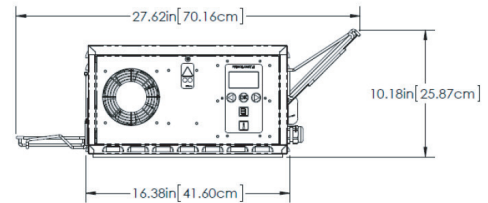
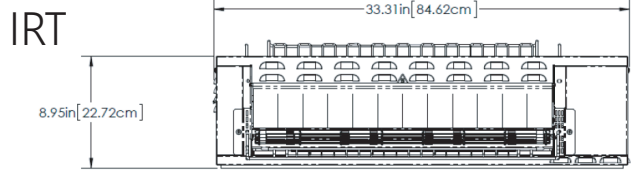

Technical Specification

Product Category	IRT Series	CBT Series
Product Dimensions	33.3"W x 8.95"H x 16.38"D (84.62)cm x (22.72)cm x (41.61)cm	33.36"W x 10.14"H x 16.11"D (84.74)cm x (25.74)cm x (40.92)cm
Shipping Weight lbs (kg)	122 lbs (55.33)kg	200lbs (90.71)kg
Shipping Volume Cubic Dimensions	11.39 (0.32)	13.0 (0.36)
Certifications	 Intertek 3183199 Conforms to ANSI/UL 197 CSA Listed CAN/CSA-C22.2 No. 109	 Intertek 3183199 Conforms to ANSI/UL 197 CSA Listed CAN/CSA-C22.2 No. 109

Model Number	Description
IRT-SB-NA-1PS	Infrared Toaster, North American version, single phase plug, 200-240v, 50/60hz, .15.5-17.75amps, Phase-1
IRT-SB-NA-3PS	Infrared Toaster, North American version, 3 phase plug, 200-240v, 50/60hz, .15.5-17.75amps, Phase-3
CBT-SB-NA-1PS	Core Bun Toaster, North American version, single phase plug, 200-240v, 50/60hz, .23.5-26.2amps, Phase-1

To learn more about **CBT & IRT Horizontal Toaster**, visit princecastle.com